

Pressione massima d'esercizio consigliata - Maximum recommended working pressure

5 bar

Temperatura massima dell'acqua consigliata - Maximum recommended working temperature

60°C

pompa.kiev.ua

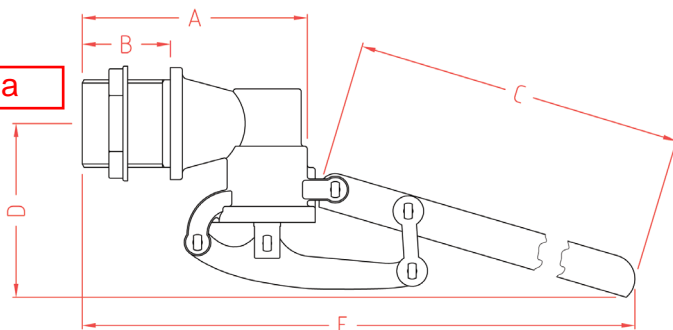

Misure d'ingombro [mm.] - Overall dimensions [mm.]

Sfera consigliata - Dimension ball recommended

DN	A	B	C	D	E
3/4"G	75	30	320	110	385
1"G	80	33	320	115	395
1"1/4G	115	44	500	120	610
1"1/2G	130	55	500	135	630
2"G	150	64	580	150	750
2"1/2G	185	70	700	280	910
3"G	185	70	700	280	910
4"G	240	80	750	300	1000

DN	In plastica		In rame	
	In plastic	In copper	In plastic	In copper
3/4"G	Ø 120	Ø 120	Ø 120	Ø 120
1"G	Ø 150	Ø 150	Ø 150	Ø 150
1"1/4G	Ø 180	Ø 180	Ø 180	Ø 180
1"1/2G	Ø 220	Ø 200	Ø 220	Ø 200
2"G	Ø 220	Ø 220	Ø 220	Ø 220
2"1/2G	Ø 300	Ø 250	Ø 300	Ø 250
3"G	Ø 300	Ø 250	Ø 300	Ø 250
4"G	Ø 300	Ø 300	Ø 300	Ø 300

Portate m³/h - Rate of flow m³/h

Pressione [bar] - Pressure [bar]

Codice - Code	Pressione [bar] - Pressure [bar]								
	0,5	1	1,5	2	2,5	3	4	5	
511/1 - 511/2 3/4"G	1,11	1,55	1,88	2,15	2,40	2,62	2,95	3,33	
511/5 3/4"G	1,12	1,61	1,95	2,26	2,52	2,76	3,18	3,57	
511/10 3/4"G	1,08	1,48	1,78	2,05	2,28	2,47	2,82	3,15	
511/1 - 511/2 1"G	0,86	1,21	1,48	1,72	1,91	2,10	2,42	2,70	
511/5 1"G	1,65	2,35	2,85	3,25	3,65	3,95	4,60	5,10	
511/10 1"G	1,50	2,10	2,52	2,92	3,30	3,55	4,08	4,53	
511/3 - 511/6 - 511/13 1"1/4G	4,90	7,35	9,00	10,55	11,95	13,15	15,15	16,85	
511/11 1"1/4G	4,45	6,95	8,45	9,70	10,80	11,75	13,30	14,75	
511/3 - 511/6 - 511/13 1"1/2G	8,70	12,40	15,00	17,30	19,20	21,00	24,20	27,20	
511/11 1"1/2G	6,30	9,00	11,05	12,70	14,10	15,40	17,80	19,70	
511/4 - 511/7 - 511/14 2"G	11,70	16,30	19,80	22,70	25,60	27,90	31,80	35,20	
511/12 2"G	10,25	14,50	17,75	20,25	22,70	24,80	28,25	31,20	
511/15 2"1/2G	15,90	22,20	27,00	31,00	34,80	38,00	43,50	48,50	
511/15 3"G	16,00	22,30	27,50	31,80	35,50	39,00	45,00	50,50	
511/16 4"G	29,50	42,00	51,50	59,30	66,20	72,30	84,00	94,00	